

NOSFET



APEX

**USER
MANUAL**

TABLE OF CONTENTS

02

Package Contents

03

Company Introduction

04-05

Diagram and Size

06-07

Specs and Software

08

Software and Suspension

09

Suspension Linkage Adjustment

10

General Maintenance

11

Display Info

12

Error Codes

13-14

Terms of Use & Warranty

PACKAGE CONTENTS

- 1 X APEX
- 1 X Charger + AC Cable
- 1 X APEX User Manual
- 1 X Suspension User Manual
- 1 X Valve Extender
- 1 X Shock Air Pump
 - (Only for Air shock installed products)

NOT YOUR ORDINARY COMPANY

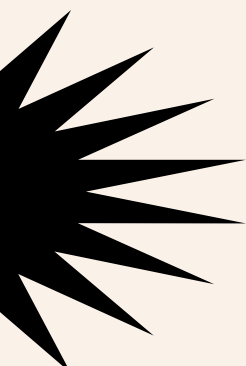

NOSFET is like a lovechild of the core team's passion and dedication. We're all in this together, pouring our hearts into a product that not only walks the talk but also dares to dream big. Our mantra? Keeping our eyes on the prize: creating an unforgettable experience for our awesome customers!



We get it, you're itching to take your snazzy new NOSFET gadget for a spin, and hey, we're all for it! But before you rev up, let's lay down some ground rules!

- Get to know every cool trick your gadget can pull off before zooming around.
- Stick to the rules of the road, abide by local laws and regulations!
- Keep it chill with the speed, following all the rules.
- Give your NOSFET buddy some regular TLC (tender loving care) AKA service and maintenance.
- Need backup? Your retailer is there for you!
- Need extra backup? Find us through our official website.
 - www.nosfet.com



APEX DIAGRAM

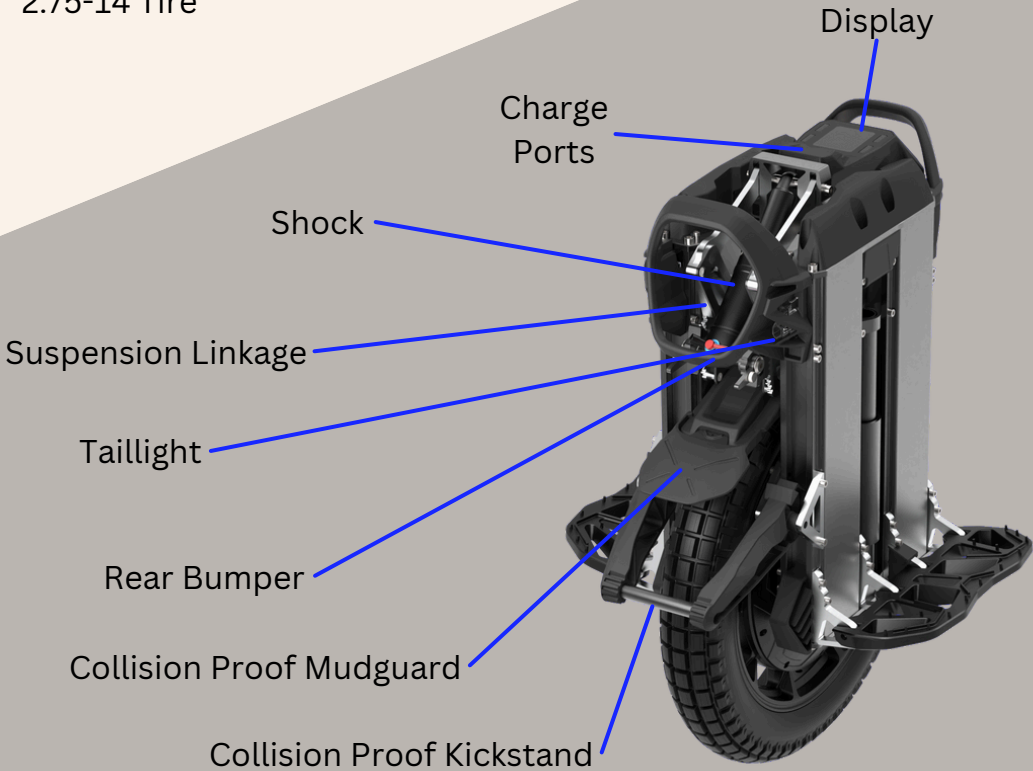
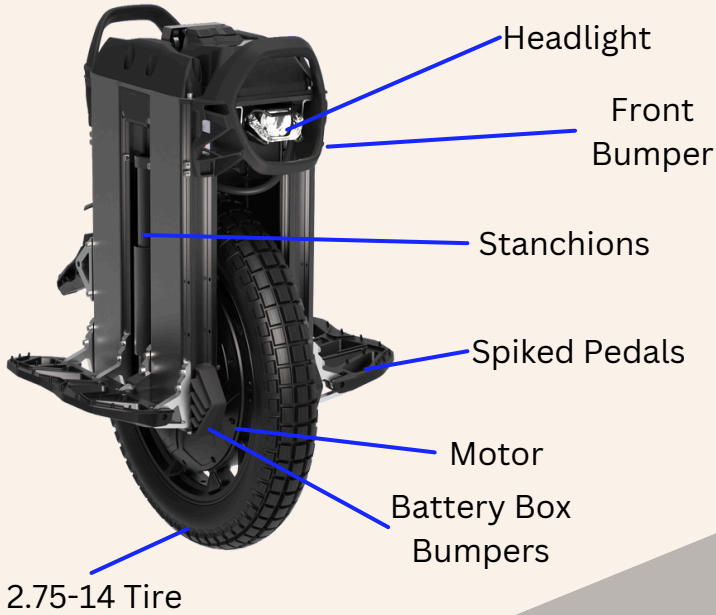

SIZE

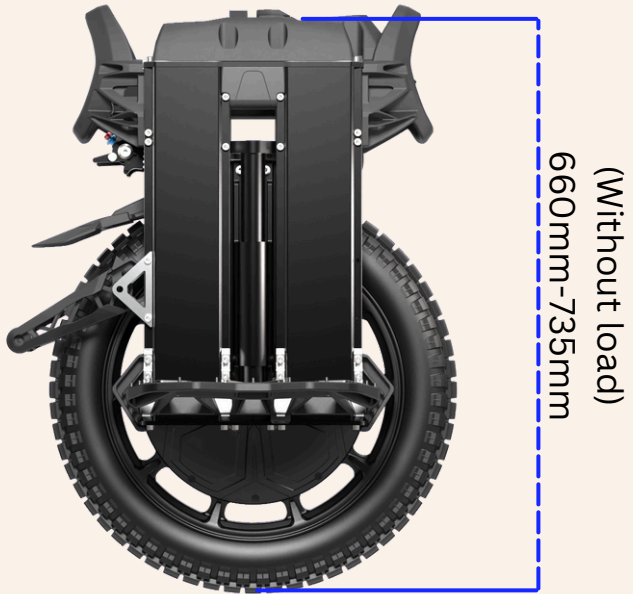
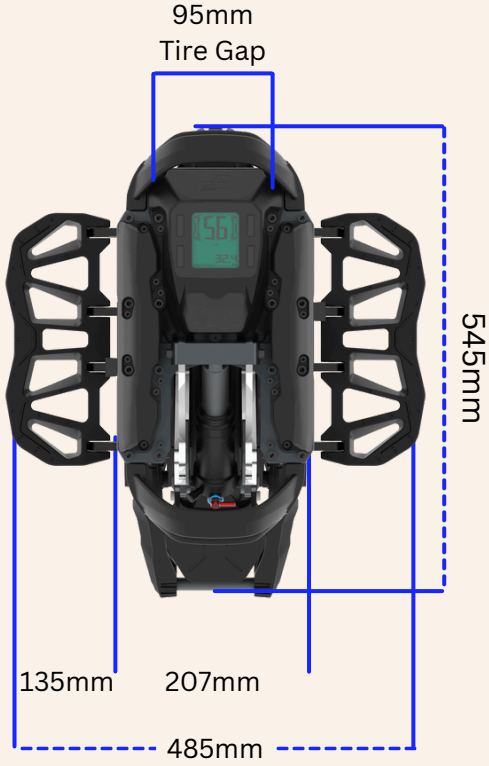

SPECIFICATIONS

Model	APEX
Free Spin Speed	125km/h
Safe Speed	19km/h
Battery	Samsung INR21700 50S 151.2v 2700wh
Charger	151.2v 5A
Charge Time	4H at 5A, 2H at 10A
Max Weight	120kg
Motor	Nominal 3200W / Peak 8000W
Tire	2.75-14
Operating Temperature	-10°C-80°C
Weight & Size Dimension	
Net Weight	39.5kg
Dimension	545 x 207mm
Hardware	
Suspension	Air Shock 205-63 Coil Shock 220-66
Controller	Dual Board, 36pc MOS, Max Current 840A
Headlight	20W
Taillight	Dual Taillight Modes - Slow Brake/Emergency Brake
Display	Speedometer, Voltage, Mileage, Battery, Ride Mode etc...
Charge Port	GX20-5 Max 15A
Motor	Magnesium Alloy Rim

Error Self Detection	Left/Right Battery: high temperature alarm, overvoltage alarm, over discharge alarm, charging current over voltage, and vehicle high temperature alarm etc...
Angle Protection	Vertical Tilt Max of 68° Horizontal Tilt can be between 35 ~75° through display.
Riding Mode	Pedal hardness value can be set between 0%-100% through display.
Power Tilt Back	Power tilt-back value could be set between 30%-100% through display
Speed Tilt Back	Speed tilt-back value can be set between 10kph-200kph through display.
Speed Alarm	Speed alarm value could be set between 10kph--200kph through display.
Button Volume	Button volume value can be set between 0-100% through display.
Low Battery Mode	Always ON
High Speed Mode	Always ON
Smart BMS	Inspecting each string of cells: 6 zones of temperature monitoring, displaying voltage etc.
Low Voltage Protection	Initial alarm at 117V, tilt back at 113.4V. Alarm at 109.8v, tilt back at 106.2V (low voltage mode).
Temperature Alarm	Alarm at 85°C (upper control board) Alarm at 105°C (lower board).

Other Functions	Multiple functions adjustable all adjustable through display, supports data logging.
Hall Sensor-less Algorithm	Detects hall sensor error and automatically fixes algorithm to allow the wheel to balancing.
Smart Field Weakening to Speed Up	Increase speed safety margin through software algorithm.
Motor Position Hold	Motor holds position and does not release when there is current with no speed.
No Hall Emergency Mode	In the event the wheel has no hall sensor the product can still continue riding with impacted performance.
APP Info	Speed, voltage, distance, trip, current, temperature etc

SUSPENSION AND MORE

SUGGESTED PSI FOR AIR SHOCK:

70KG AND BELOW: 200 PSI
70-80KG: 250 PSI
80KG+: 275 PSI

PSI are only suggested guidelines, you should set the rebound, compression and PSI according to your own preference.

Mudguard

The mudguard is designed to take impact without breaking. The screw holds the rear mudguard in place. On impact it may shift to reduce impact, it can be easily re-adjusted by hand.

Kickstand

The kickstand is designed to be collision proof, meaning that it will go from it's lower position to a higher position in the event of a collision.

SUSPENSION LINKAGE ADJUSTMENT

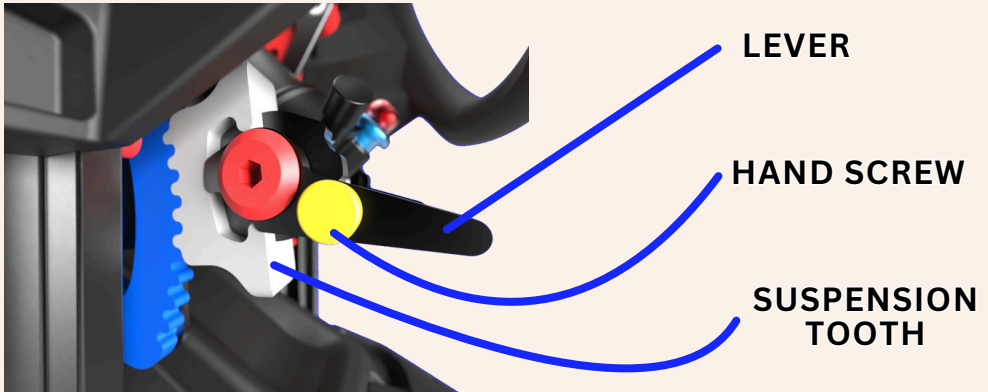

To adjust the height and suspension travel please follow this procedure:

1. Loosen the **hand screw** (yellow).
2. Lift the wheel with the front and rear bumpers to **shake the suspension tooth loose**.
3. Pull the lever downwards, pull the suspension tooth module outwards.
4. Once the suspension is loose, **set to desired height**.
5. Ensure suspension tooth is the **same height on both sides** and secure by pushing the lever upwards.
6. **IMPORTANT! Lastly completely tighten suspension hand screw**

[Need additional help? Check out our Youtube Channel](#)

GENERAL MAINTENANCE

Battery:

- Please store battery away from direct sunlight and heat.
- For prolonged storage and extended health please store the battery between: 30%-70%.

Tire:

- Please keep tire well inflated to prevent damage to the rim.
- Inspect the tire before each ride, ensure it's free from cracks and punctures and has enough tread.

Suspension:

- Please refer to shock manual for maintenance guidelines.
- Stanchions should be lubricated every 500kms.

DISPLAY INFO

Speedometer

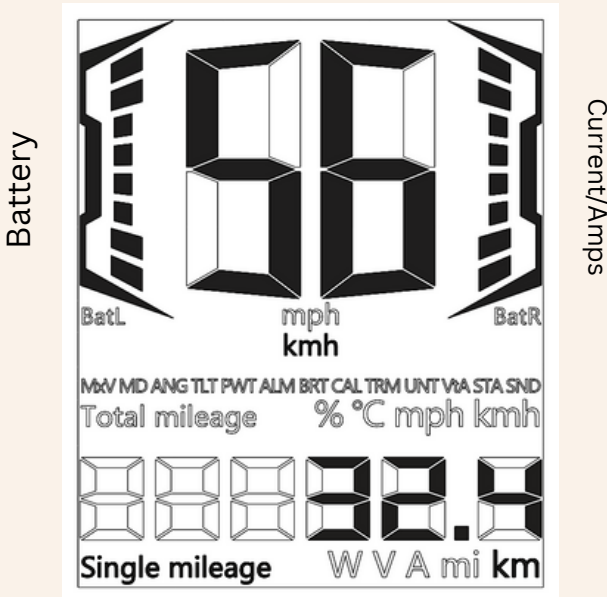

W: Watts V: Voltage A: Amps/Current mph: miles/h kmh: kilometers/h

Adjusting Settings

1. Press **OK** for 5 seconds until beep.
2. Pick setting you want to adjust by pressing **>**
3. Adjust the setting by quick pressing **OK**.
4. Press **OK** until beep, to go backwards.
5. Save by holding **OK for 5 seconds**, or **wait 25 seconds**.



MD: Ride Mode
ANG: Vertical Angle Adjustment
TLT: Tiltback Speed
PWT: PWM Value
ALM: Alarm Speed
BRT: Brightness
CAL: Calibration

TRM: Transport Mode
UNT: Unit
VtA: Voltage Adjustment
STA: Side Tilt Angle (L/R)
SND: Volume Adjustment
MxV: Max Charge Voltage
ANG %: Acceleration Assist
ALM: Torque Alarm(ON/OFF)

High Speed Mode and Low Battery Mode are on by default.

ERROR CODES

Code	Issue
br tEñ	Right Battery Pack High Temperature Alarm
bl tEñ	Left Battery Pack High Temperature Alarm
bt LoY	Battery Pack Over Alarm
u HCGH	Battery Pack Overpressure Alarm
E CHAr	Charging Current Exceeds the Set Value
E HALL	Motor Hall Error Alarm
t HCGH	Controller High Temperature Alarm

Need additional help?

Please contact your official NOSFET retailer for assistance or email us at support@nosfet.com

TERMS OF USE

SUPPORT: Please contact your retailer first before emailing us at: support@nosfet.com

The following persons are prohibited from riding this product:

- Persons who are under the influence of drugs or alcohol and have limited mobility and reaction ability.
- Additionally, any persons with; hypertension, cardiovascular and cerebrovascular diseases or other high-risk diseases.
- Minors under 16 years old, pregnant women, mentally ill and the elderly over 60 years old.

Additional Terms:

- This product is not allowed to be disassembled or repaired by uncertified personnel. If the machine is disassembled by uncertified personnel the warranty service will be voided.
- If the NOSFET product produces an **alarm sound**, please stop riding it immediately and send it to certified NOSFET retailer for maintenance immediately, continued use without repair will void the products warranty.
- **Such actions are prohibited** when using this product:
 - Hard acceleration, especially at below 60% battery.
 - Riding backwards in public space.
 - Riding one footed or performing other acrobatics.
 - Carrying items or other people.
- **ALWAYS WEAR SAFETY GEAR:** full face helmet, elbow and knee protection, chest guard and wrist guards are mandatory.
- During the production or sale of this product, design changes and further improvements will be carried out continuously. In case of any discrepancy with this manual, please refer to the actual product.

WARRANTY

SUPPORT: Please contact your retailer first before emailing us at: support@nosfet.com

Controller: 24 months

Battery Packs: 18 months

Charger: 6 months

Suspension Shock: Refer to manufacturer's user manual.

NOTE: NOSFET warranty only includes providing the relevant parts for repair and does not include labour costs for repair, logistical and any additional expenses. Please speak with your NOSFET retailer for details.

The following conditions are not covered by the warranty:

- Warranty period has expired.
- Damage caused by human factors.
- Damage caused by force majeure.
- All kinds of damage caused by failure to use product according to manual, maintenance, modification of NOSFET products.
- Failure or damage caused by forced use of this product beyond normal conditions.
- The product has been disassembled or maintained by personnel not authorized by NOSFET.
- Malicious damage to warranty content and product.



THANK YOU

WWW.NOSFET.COM

**FOLLOW US ON SOCIALS.
TAG US IN YOUR CONTENT!
RIDE SAFE.**